



» Noise Resist



The Profile System



The Clean-Room System



Safety Barriers

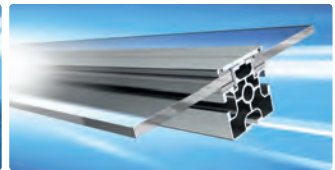

The Modular Wall System



The Tube Clamping System



The Telescopic System

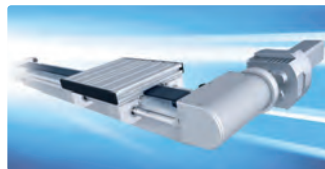

The Linear System

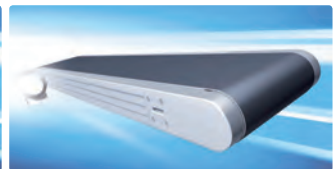

The Conveyor System



The Personnel Transfer System



The Skid Transfer System



The Dust Protection System



The Pipe & Joint System



The Trailer System

powered by

MayCAD
Design Software

MayTube
Design Software

The ideal profile system

MayTec offers a comprehensive, harmonised profile system. All profiles can be combined in any way conceivable.

The accessories provide functional and aesthetic solutions for a wide range of applications.

Applications

- machine bases
- machine enclosures
- machine guarding
- work stations

Service

The MayTec service is as versatile as the MayTec profile system.

You may choose:

- delivery of standard elements ex-factory
- delivery of profiles and accessories cut to size according to parts list for customer's assembly
- delivery of pre-fitted modular components
- delivery of completely assembled units
- assembly at your premises

- assembly and inspection stations
- transfer and supply trolleys
- partitions and protective walls
- protective and work cabinets

Implementation

The MayTec profile system is easy to process and quick to assemble. Its flexible and modular construction means it can be easily modified and is reusable at any time.

An experienced team will support you in implementing the MayTec system, tailored to your individual applications, taking into consideration your dimensions, loading capacity and stability.

- special shelves
- plant equipment
- display systems
- exhibition cabinets and stands



MayTec GmbH plant in Olching



Accessory storage

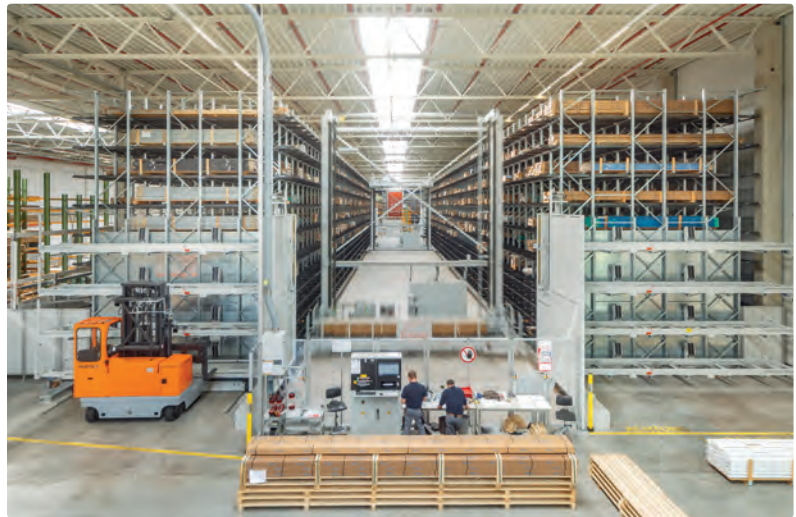

Stock of aluminium profiles



Panel storage



Profile machining

1	Introduction.....	5
1	Is this your situation ?	5
2	MayTec "Noise Resist"	6
2	General	6
2.1	1-layer "Noise Resist" made of 1 mm aluminium.....	7
2.2	2-layer "Noise Resist" absorber made of 1 mm aluminium and acoustic foam	8
2.3	3-layer "Noise Resist" wall elements.....	12
2.4	Acoustical enclosure questionnaire	14
3	Design for silence	15
3.1	Treat source of noise.....	15
3.2	Treat noise path.....	15
3.3	Treat receiver environment	16
4	Fundamentals of acoustics.....	17
4.1	Acoustic velocity	17
4.2	Acoustic pressure	17
4.3	Acoustic pressure level	18
4.4	Sound absorption	18
4.5	Sound absorption coefficient	19
4.6	Reverberation time.....	19
4.7	Sound propagation	19
5	Absorbers and resonators.....	20
5.1	Perforous absorber	20
5.2	Panel resonator	20
5.3	Helmholtz resonator	20

Is this your situation ?

- you need to reduce the noise emission of your machinery
- you need to improve the noise reduction of your existing sound enclosure
- you do not want delicate foam surfaces in your sound enclosure
- you are looking for an aesthetic fiber free solution
- you want to build your machine enclosure with the most functional and rugged aluminium profile system utilizing the highest level of design freedom
- You need to reduce your ambient noise (diffuse sound)

⇒ **We understand**

General

The patented MayTec "Noise Resist" sound absorber combines the advantages of perforous absorbers with the advantages of resonators (please find detailed information on absorbers and resonators on page 20).

The MayTec "Noise Resist" absorber acts on a broadband frequency range like a perforous absorber and at the same time offers the small thickness of resonators.

The MayTec "Noise Resist" absorber can consist of 1, 2 or 3 layers of different materials:

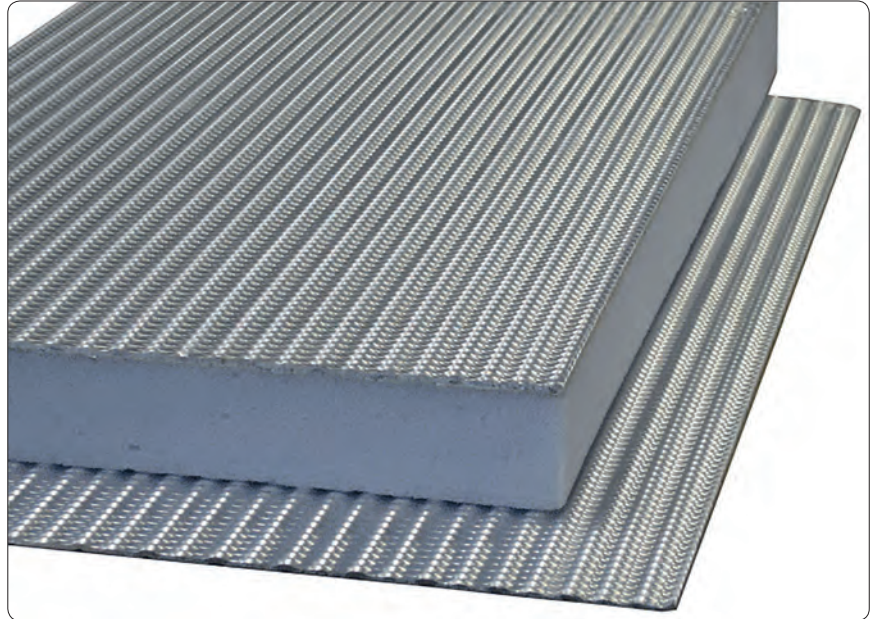

MayTec 1-layer "Noise Resist" made of 1 mm aluminium

Is a self supporting aluminium sheet, which is micro-perforated by a patented process to generate the optimum airflow resistance for absorbing sound.

In order to optimize the efficiency of the MayTec 1-layer "Noise Resist" absorber, it is normally installed with a small airspace between the absorber panel and the back wall.

The main advantages of the MayTec "Noise Resist" absorber are:

- extremely robust
- dirt and fluid resistant
- easily cleaned, even with steam cleaners
- heat resistant
- non-combustible
- chemically stable
- wear resistant
- can be recycled
- aesthetic appearance
- paintable in any colour
- fiber free

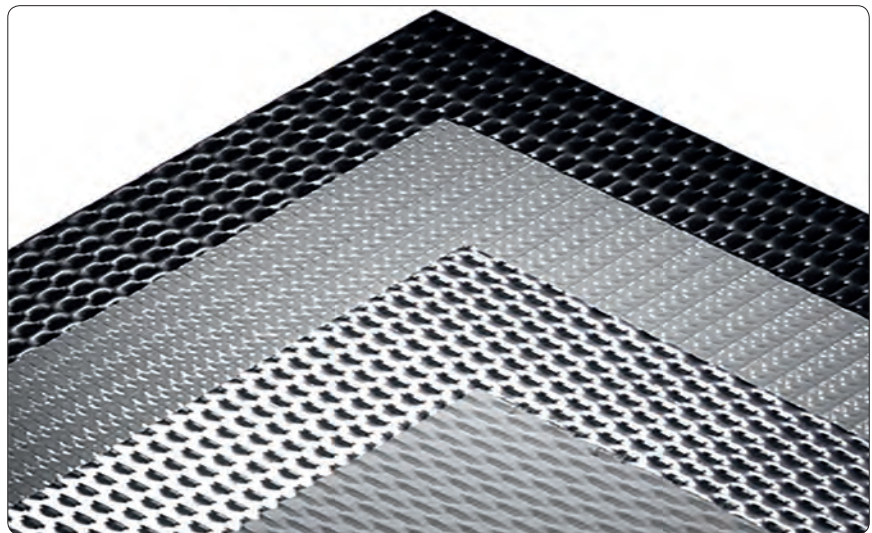

The MayTec 1-layer "Noise Resist" achieves the highest noise reduction for frequencies between 1,000 Hz and 3,000 Hz. This is exactly the frequency range of most technical applications (motors, pumps, compressors, ventilators, etc...). By increasing the airspace of the MayTec 1-layer "Noise Resist" to the back wall it is possible to increase the noise reduction dramatically in the lower frequency range to about 1,700 Hz (as per the following diagram)

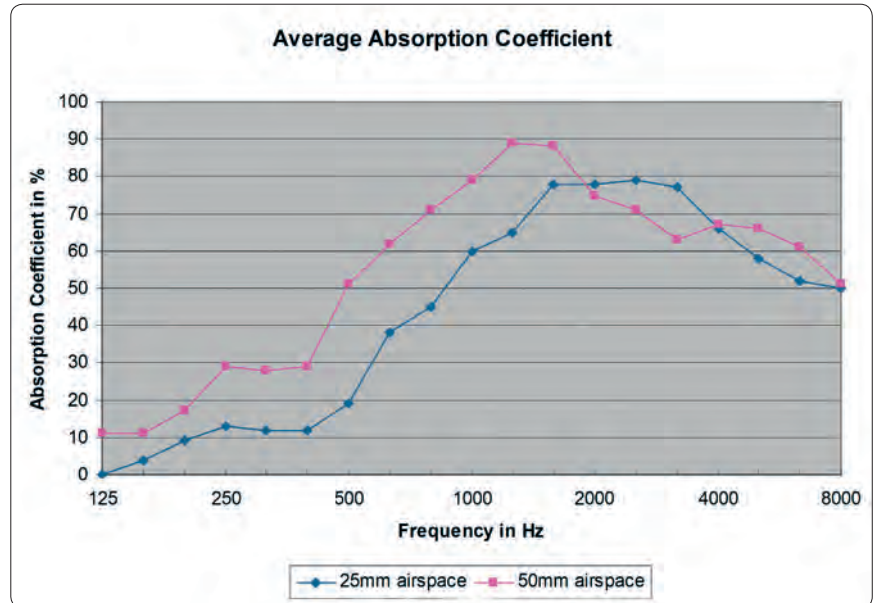

Average absorption coefficient of the MayTec 1-layer "Noise Resist"

Application Reference

Food preparation areas are usually extremely hard areas to treat noise due to hygiene requirements which stipulates that all materials and surfaces have to be non absorbent and easy to clean. So a food processing factory typically shows a high ambient noise level due to the lack of sound absorbing surfaces.

The pictures show an installation at company Dafgård in Sweden. In this case no more than 10% of the walls were covered with the MayTec 1-layer "Noise Resist" absorbers. With this installation the ambient noise level was reduced by an average of 5 dB.



The post formed "Noise Resist" absorbers are attached to hinged wall frames so that they can be steam cleaned from both sides.

MayTec 2-layer "Noise Resist" absorber made of 1 mm aluminium and acoustic foam

The MayTec 2-layer "Noise Resist" absorber consists of the 1 mm thick, micro-perforated aluminium sheet attached to a special acoustic foam. The MayTec 2-layer "Noise Resist" absorber is available with 2 different foam thicknesses: 25 mm and 50 mm (≈ 1" and 2").

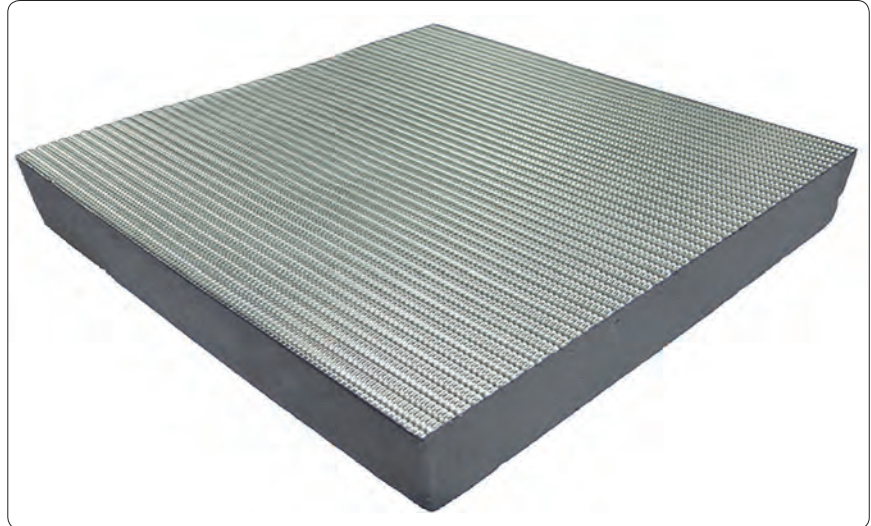

The combination with the acoustic foam significantly increases the noise reduction of lower frequencies compared to the 1-layer "Noise Resist" absorber (see following diagram).

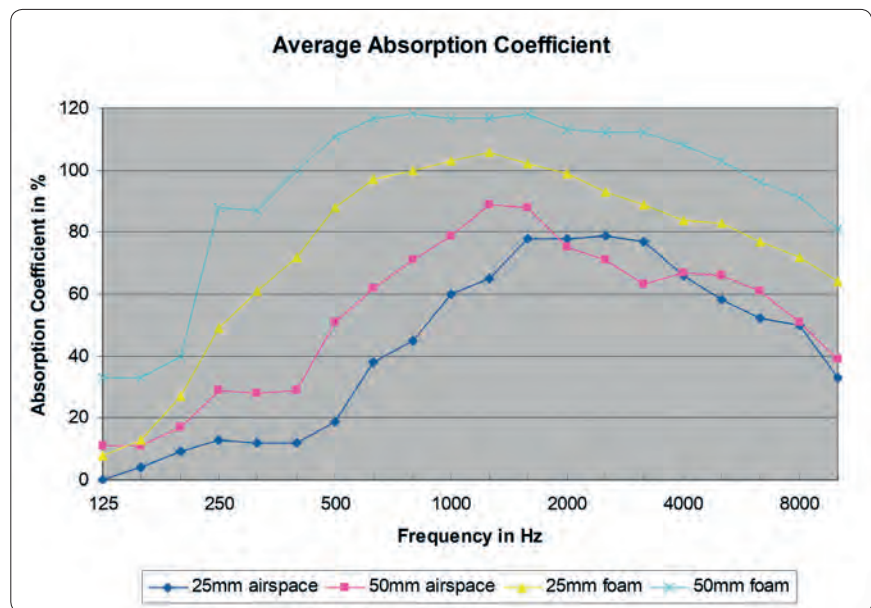

For easy assembly to walls or machine enclosures the back of the acoustic foam has a "peel off" sticky surface.

After the assembly the aluminium surface faces the noise source.



The main advantages of the MayTec 2-layer "Noise Resist" absorber are:

- increased noise reduction of lower frequencies
- elimination of the absorber's resonance frequency by combining 2 different materials (double glazing effect)
- the acoustical foam is non-combustible and heat resistant
- the aluminum surface prevents fluids from entering unless they are under high pressure and the acoustic foam can be treated (at an extra cost) to be water and oil resistant
- well protected against mechanical damage, as the aluminum surface is facing inside
- available in 25 mm and 50 mm thick acoustic foam
- easy assembly due to peel off adhesive surface on the back of the foam

Application Reference

Typical technical applications are sound enclosures of pumps, generators, compressors or motors.



Remark:

When the MayTec "Noise Resist" absorber is glued onto a panel element of an enclosure, it is absolutely important to remember, that the panel element has a high stiffness. Otherwise low frequencies will stimulate vibration of the complete panel element. In this case the panel element would work as a "loudspeaker" and would be acoustically transparent for low frequency sound. So it is recommended to use a panel element with a high mass (e.g. 2 mm steel).

MayTec 3-layer "Noise Resist" wall elements

For the assembly of sound isolation rooms or sound enclosures, MayTec offers modular wall and ceiling elements with the 3-layer "Noise Resist" absorber.

The outside shell of the wall element consists of a 2 mm steel sheet. The middle of layer is made of 50 mm acoustic foam. The innermost layer is the 1 mm thick perforated aluminium sheet.

The 3-layer MayTec "Noise Resist" absorber panels are framed with a 40×40 profile structure to generate a compact and rugged wall or ceiling element.

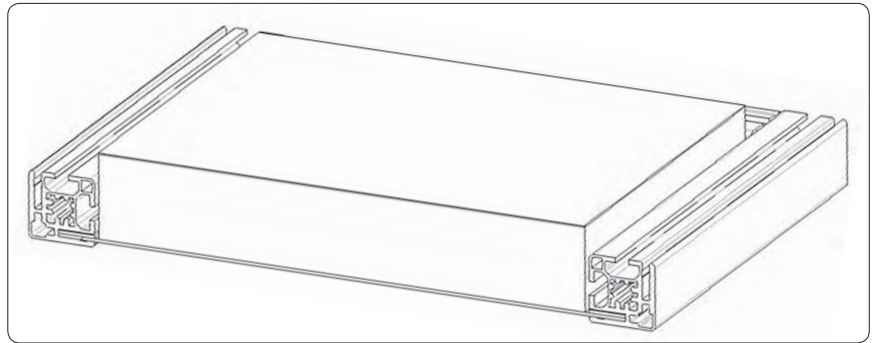

The first step for the installation of sound enclosures or sound isolation rooms is to align the posts made of 80×80 profiles and to bolt them to the floor.

Afterwards the connector heads which are sticking out of the pre-assembled MayTec "Noise Resist" wall elements are slit into the slots of the posts and the connectors are tightened.

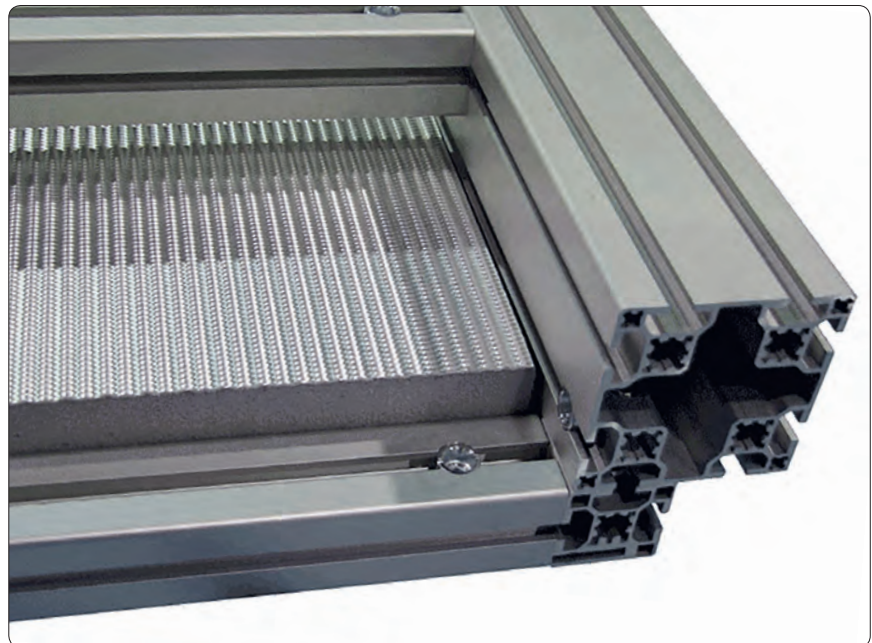
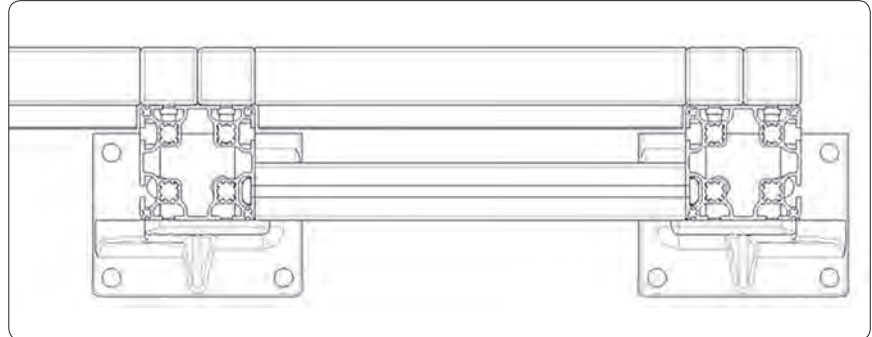

The modular design of the MayTec "Noise Resist" wall elements guarantee an easy and fast assembly of sound isolation rooms and sound enclosures.

Insertion Loss Calculation Guidelines

The following data sheet allows you to estimate the achievable insertion loss of a sound enclosure built with the MayTec "Noise Resist" wall elements:

Noise character Type of enclosure	rumble	roar	screech
	(low tone)	(midtone)	(treble)
no openings	15 dB	25 dB	35 dB
2 or more openings	10 dB	15 dB	20 dB
no roof	4 dB	10 dB	15 dB

Acoustical enclosure
questionnaire

1. Do you have a current noise level measurement without the MayTec "Noise Resist"
..... dB
2. Do you have a spectrum of the noise?
 125 Hz 250 Hz 500 Hz 1 kHz 2 kHz 4 kHz 8 kHz
In case the frequency is not known, please specify the noise character:
 rumble (low tone) roar (midtone) screech (treble)
3. Do you have a noise target or noise reduction target? dB
4. Access requirements:
 for product removal
 infeed of raw material
 power cables and hoses
 for visual monitoring
 for maintenance access
5. Cooling requirements (only needed for complete enclosures)
- what type of motors drive the machine
total HP kW
- are there any cooling or heating devices
total heat generated
6. Sketch of enclosure

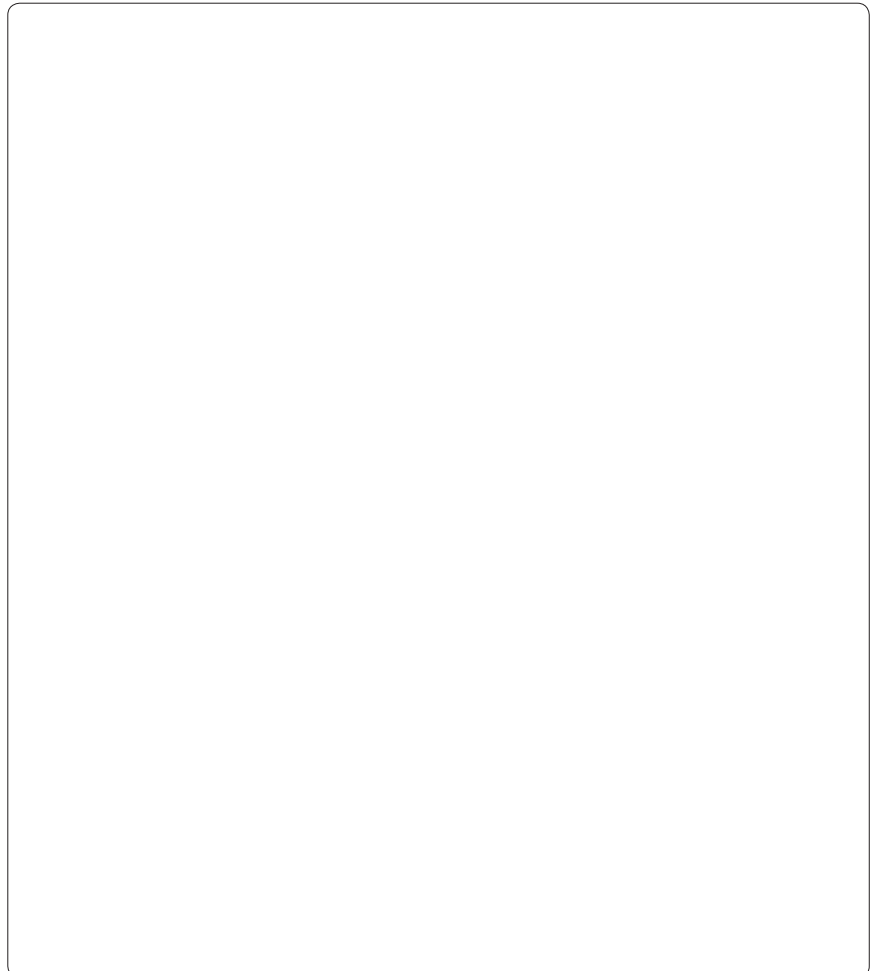

Design for silence

The acoustic methodology to reduce noise shows 3 main approaches:

1. Treat source of noise
2. Treat noise path
3. Treat receiver environment

The cost for the noise reduction increases from point 1 to 3:

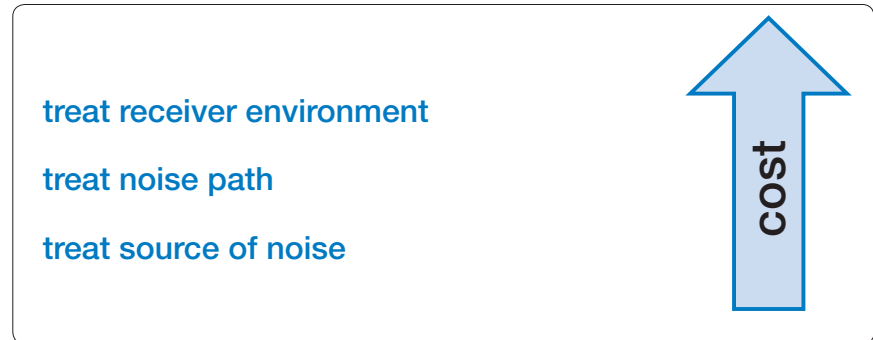

3.1 Treat source of noise

Typical noise sources are:

- cooling fans
- motors / generators
- impacts
- cutting
- compressed air
- chains and pulleys

Treating the noise source is usually the most cost effective approach in the long run, because every source emits noise on many paths simultaneously.

Reducing the speed of cooling fans achieves an extreme reduction of the sound pressure:

$$\text{Sound pressure } P \propto \text{Revolution speed } N^6$$

As well always try to avoid struts close to fan blades.

3.2 Treat noise path

In order to optimize the noise path the following most important approaches should be used:

- minimize the holes in the sound enclosure
- increase the mass of the sound enclosure (especially for low frequencies)
- isolation of vibrations
- reduction of vibrations

By far the most effective approach is to minimize the holes in the sound enclosure. The following diagram shows how significantly possible sound transmission loss depends on the percentage of holes in the sound enclosure.

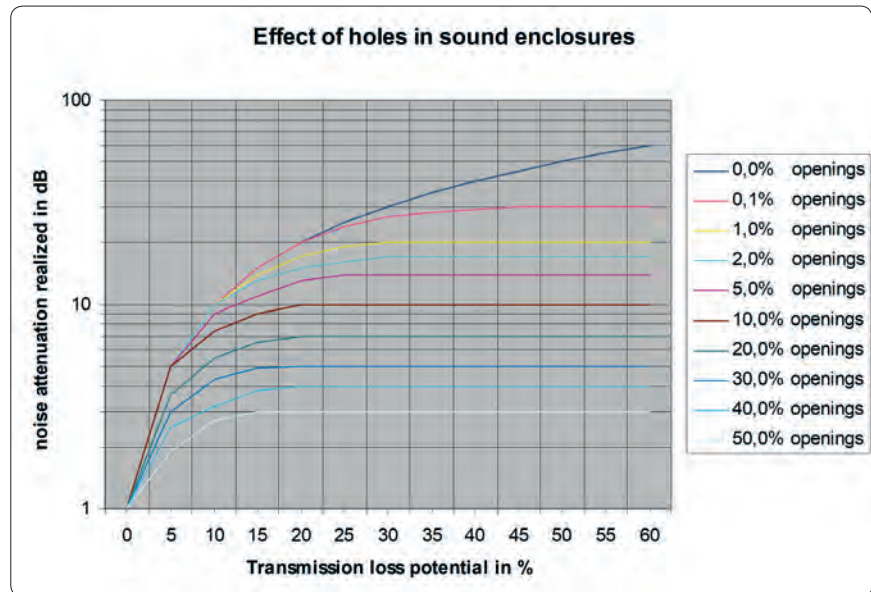

The diagram shows that a sound enclosure with a transmission loss potential of 50%

- with 0.1% openings allows a sound transmission loss of 30 dB
- with 1% openings allows a sound transmission loss of 20 dB
- with 10% openings allows a sound transmission loss of 10 dB

3.3 Treat receiver environment

In this case the direct emitted noise from the source has to be reduced as well as the diffuse noise generated by reflections

- installation of additional absorbers and noise barriers close to the operator
- installation of absorbers at the walls and ceilings

In rooms with a low ratio of sound absorbing surfaces a small amount of additional sound absorbing surfaces will create a significant sound pressure reduction.

In rooms with a high ratio of sound absorbing surfaces a much larger amount of additional sound absorbing surfaces are necessary to further reduce the sound pressure.

The 1-layer MayTec "Noise Resist" absorber is a perfect solution to this problem. As described in the application reference on page 4 of company Dafgård, only 10% of the walls needed to be covered with the MayTec 1-layer "Noise Resist" absorber to reduce the sound pressure by an average of 5 dB. This means, that the acoustic pressure level was almost reduced by half.

Fundamentals of acoustics

- 4.1 Acoustic velocity
- 4.2 Acoustic pressure
- 4.3 Acoustic pressure level
- 4.4 Sound absorption
- 4.5 Sound absorption coefficient
- 4.6 Reverberation time
- 4.7 Sound propagation

4.1 Acoustic velocity

Acoustic velocity is the speed of sound inside a special material

$$c = \lambda \cdot f$$

shortcut	unit	SI-unit
c	acoustic velocity	m/s
λ	wave length	m
f	frequency	Hz

Examples of acoustic velocities in different materials:

air	344 m/s
water	1,480 m/s
iron	5,000 m/s
steel	5,050 m/s
aluminium	5,200 m/s
concrete	3,100 m/s
Polystyrol	1,800 m/s
PVC soft	80 m/s
Plexiglass	1,840 m/s
quartz glass	5,400 m/s

4.2 Acoustic pressure

The acoustic pressure p is an alternation pressure, caused by the sound wave, which superposes with the static air pressure. Determined is not the instantaneous but the effective acoustic pressure which is the temporary quadratic average $p(t)$.

$$p_{\text{eff}} = \sqrt{\frac{1}{T} \cdot \int_0^T p^2(t) dt}$$

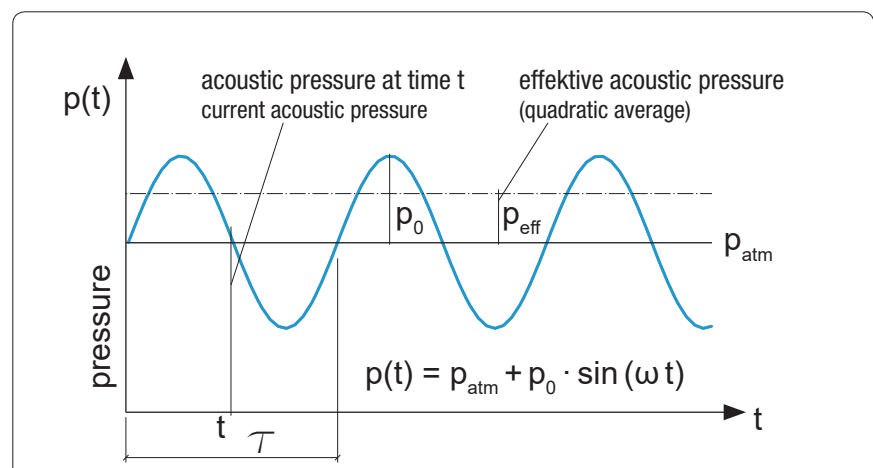

4.3 Acoustic pressure level

In order to easier visualize values which differentiate by decimal powers the unit "Acoustic pressure level" L was established.

For this the common logarithm of the quotient of the acoustic pressure p and a reference acoustic pressure p_0 .

The reference acoustic pressure p_0 is the acoustic pressure at the auditory threshold at 1 kHz. Although the acoustic pressure level L has no dimension the unit "Bel" (1 B) is used. In the daily practice the unit decibel (1 dB = 0.1 B) is more common.

Due to the logarithmical scale (dB-scale) it is now possible to display the large acoustic pressure range from 1 (auditory threshold) to 1 million (pain threshold) as manageable series of numbers from 0 dB (auditory threshold) to 120 dB (pain threshold).

$$L = 10 \cdot \lg \left(\frac{p^2}{p_0^2} \right)$$

shortcut	unit	SI-unit
L	acoustic pressure level	dB
p	acoustic pressure (effective value)	Pa
p_0	Bezugsschalldruck	Pa

Acoustic pressure level of sounds

0 dB	auditory threshold
10 dB	just hearable sound
15 - 20 dB	low swoosh of leaves
30 - 40 dB	silent living area
40 - 50 dB	soft speaking, quiet office
50 - 60 dB	normal conversation
70 - 80 dB	heavy traffic
80 - 85 dB	calling, shouting
80 - 90 dB	truck driving past, lawn-mower in 10 m distance
90 dB	maximum voice capacity
90 - 100 dB	jackhammer in 10 m distance
100 - 110 dB	express train driving past
115 dB	trumpet (fortissimo)
110 - 120 dB	boiler shop
120 - 130 dB	propeller plane in 3 m distance, painful noise

4.4 Sound absorption

When sound energy (sound waves) impacts on a surface, a part of it is reflected (sound reflection), a part of it transmitted (sound transmission) and a part of the energy is converted into heat (sound dissipation).

The sum of transmitted and dissipated energy is called absorbed sound energy (sound absorption).

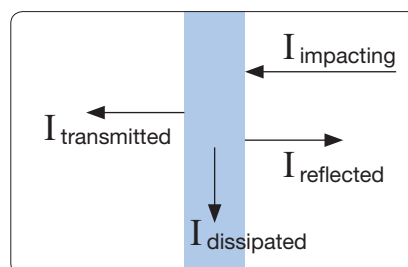

Increasing the sound absorption inside a room reduces the acoustic pressure level in that room. But this reduction of the acoustic pressure level is limited to diffuse sound. Close to the noise source the direct noise prevails. The direct noise can not be reduced by absorption.

In rooms with low ratio of sound absorbing surfaces a small amount of additional sound absorbing surfaces will create a significant sound pressure reduction. In rooms with a high ratio of sound absorbing surfaces a much larger amount of additional sound absorbing surfaces are necessary to further reduce the sound pressure.

4.5 Sound absorption coefficient

The sound absorption coefficient α specifies the ability of a material to absorb sound energy.

$$\alpha = \frac{I_{\alpha \text{ absorbed}}}{I_{e \text{ impacting}}}$$

The sound absorption coefficient α is always depending on the frequency of the sound.

$\alpha = 0$ complete reflection of the sound energy

$\alpha = 1$ complete absorption of the sound energy

4.6 Reverberation time

The reverberation time T is the time in seconds in which the sound pressure level is reduced by 60 dB after the source is switched of. So the time which is necessary to reduce the sound energy down to 1/1,000,000 of it's original value.

The reverberation time T is always depending on the frequency of the sound.

4.7 Sound propagation

During the sound propagation in rooms there is not only the sound coming straight from the source (direct sound), but due to reflections at walls, ceilings, floor and equipment in the room. So a diffuse sound field is generated. The diffuse sound is equally distributed throughout the room.

Close to the source the direct sound prevails, but it's ratio decreases significantly with an increasing distance to the source.

In some distance to the source the diffuse sound prevails.

5.1 Perforous absorber

Perforous absorbers are components with a porous surface. When sound waves impact on the surface of a perforous absorber, the sound waves enter the pores and channels of the absorber and cause the air in the pores to oscillate. Friction and flow resistance in the pores lead to the conversion of sound energy into thermal energy.

The most effective sound absorption can be achieved when the perforous absorber is placed in a distance of $\lambda/4$ off the reflecting wall.

The lowest frequency of an absorption maximum is at

$$f_1 = \frac{85}{a}$$

shortcut	unit	SI-unit
f_1	Frequency of the lowest absorption maximum	Hz
a	Distance between wall surface and centre of the perforous absorber	m

Increasing the wall distance of a perforous absorber moves the absorption maximum to lower frequencies.

5.2 Panel resonator

A panel resonator is a flexible plate mounted at a wall with a certain distance. A panel resonator is a specific spring-mass-system which is stimulated to oscillate by impacting sound waves.

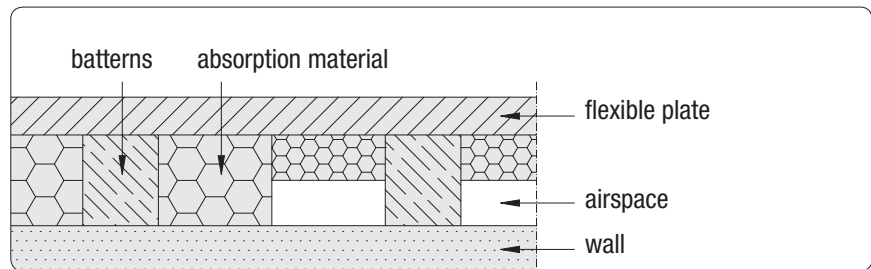

The effect of a panel resonator is caused by sound waves impacting on the flexible panel. The oscillation of the flexible plate is converted into thermal energy. A panel resonator is only able to absorb sound within a specific, narrow frequency range of its own resonance frequency. The resonance frequency of the panel resonator is specified by the combination of materials used.

5.3 Helmholtz resonator

A Helmholtz resonator is a perforated plate which is mounted at a wall with a certain distance. A Helmholtz resonator is also a specific spring-mass-system, same as a panel resonator, which gets stimulated to oscillate by impacting sound waves.

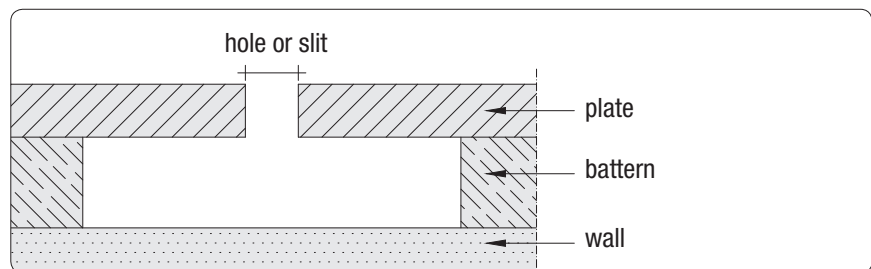

The air plugs in the holes are stimulated to oscillate by the impacting sound waves. Same as a panel resonator, the Helmholtz resonator also only works around its resonance frequency in a narrow frequency range.

Imprint

Subject to technical modification.

All rights reserved.

Copying - also in parts - only allowed by
written consent.

© MayTec Aluminium Systemtechnik GmbH,
Germany, D - 82140 Olching, 2019

The key ...

to success

extremely strong

efficient

functional

Australia

MayTec Australia P/L
Unit 8, 175 James Ruse Drive
Rosehill, NSW 2142

country code: +61
phone (0)2/9898 9929
fax (0)2/9638 4086
info@maytec.com.au
www.maytec.com.au

Germany

MayTec Aluminium
Systemtechnik GmbH
Gewerbering 16
D-82140 Olching

country code: +49
phone (0)8142/6540-0
fax (0)8142/6540-119
mail@maytec.de
www.maytec.de

USA

MayTec Inc.
901 Wesemann Drive
West Dundee, IL 60118

country code: +1
phone 847-429-0321
fax 847-429-0460
mail@maytecinc.com
www.maytecinc.com

MayTec distributor